



AN013703-0708



Abstract

This Application Note demonstrates Zilog's Z8 Encore![®]-based battery charger that charges various rechargeable batteries in a fast, efficient, and safe manner.

All the important rechargeable battery types, Sealed Lead Acid (SLA), Nickel Cadmium (NiCd), Nickel Metal Hydride (NiMH), and Lithium Ion (Li-Ion), are addressed in this Application Note. The Z8 Encore!-based charger manages each battery type according to its individual charging profile.

► **Note:** *The source code file associated with this application note, AN0137-SC01.zip is available for download at www.zilog.com.*

Product Overview

Z8 Encore! products are based on the new 8-bit eZ8 CPU, and introduce Flash memory to Zilog's extensive line of 8-bit microcontrollers unit (MCU). The Flash in-circuit programming capability allows for faster development time and program changes in the field. The new eZ8 core maintains backward compatibility with Zilog's popular Z8[®] MCU.

Featuring Zilog's high performance register-to-register based architecture (eZ8), the new Z8 Encore! MCUs combine a fast 20 MHz core, up to 64 KB of Flash memory, up to 4 KB of linear register SRAM, and an extensive array of on-chip peripherals. These peripherals make Z8 Encore! suitable for a variety of applications including motor control, security systems, home appliances, personal electronic devices, and sensors.

Features

The features of Z8 Encore! are as follows:

- New high-performance 20 MHz eZ8 CPU
- Up to 64 KB Flash memory with in-circuit programming capability
- Up to 4 KB register SRAM
- 12-channel, 10-bit analog-to-digital converter (ADC)
- Two full-duplex UARTs
- Two Infrared Data Association (IrDA) compliant endecodes
- SPI and I²C ports
- Four 16-bit timers with capture, compare, and PWM capability
- Watchdog Timer (WDT) with internal RC oscillator
- 3-channel DMA
- Up to 60 I/O pins
- 24 interrupts with configurable priority
- On-Chip Debugger
- Voltage Brownout protection (VBO)
- Power-On Reset (POR)

The Z8 Encore! CPU is capable of a nominal 10 MIPs throughput at 20 MHz. The 4 KB SRAM extends the Z8 Encore!'s reach to a wider range of applications. The 10-bit sigma/delta ADC provides high measurement resolution, and the SPI, UART, and I²C interfaces can be used concurrently. The versatile DMA controllers can be configured in many useful combinations to free the CPU from performing unnecessary data transfer overhead.

Discussion

A discussion on designing a battery charger is presented in this section. For further details, see [Reference](#) on page 8.

Theory of Operation

When designing a battery charger, the following aspects are considered:

- Power control techniques to suit different battery types and capacities.
- Charging and charge termination techniques to avoid overcharging, thus facilitating fast charging.
- Safety techniques to ensure safe operation throughout the charging process.

These aspects are discussed in the following section.

Power Control Techniques

At the core of a battery charger is the DC–DC converter that acts as a regulated power source. The charger hardware is capable of regulating its output in various modes, such as constant voltage, constant current, or constant voltage with a current limit. The charger can be viewed as a control system in itself.

In [Figure 1](#), an initial setpoint is a charger output value chosen by you. In a battery charger, the type and capacity of the battery is the determinant of the mode of operation—namely, a constant current source or a constant voltage source. It also determines the required current and voltage setpoints. These setpoints can be expressed as I_{SET} or V_{SET} .

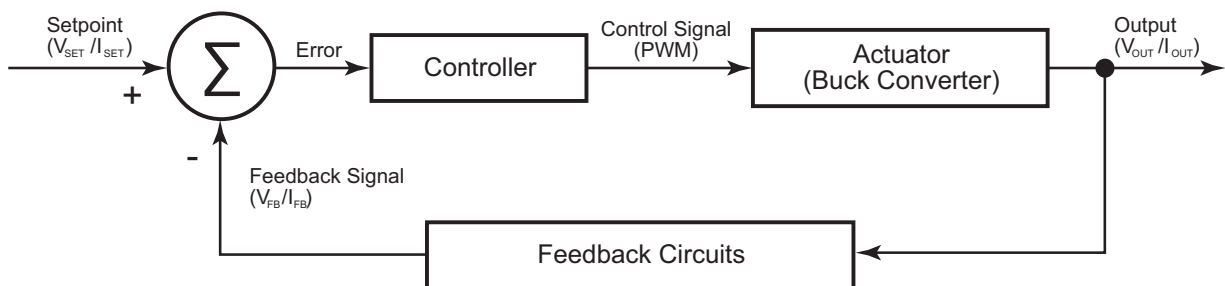

Figure 1. Feedback Control System

The feedback circuits displayed in [Figure 1](#) measures actual output. The difference between the initial setpoint and the actual value (feedback signal) is called an error. The controller generates a control signal according to the magnitude and direction of the error. It minimizes the steady state error and also responds quickly to transient fluctuations during input or output. Controllers usually work at lower power levels and therefore require an external actuator to generate the appropriate output.

In a battery charger, the actuator is a step-down DC–DC converter, also known as a buck converter. The buck converter converts a higher DC voltage to a lower one depending on the Pulse Width Modulated (PWM) control signal generated by the controller. The frequency of the PWM signal is maintained at a constant while the width of the pulse or the duty cycle of the signal varies. This variation is reflected as a change in voltage and/or current at the output.

Controllers are differentiated according to the way they handle errors generated during regulation of

the system output (in the case of a charger, these errors are either voltage or current errors). In a proportional controller, the actual value and the set value are compared, and the resulting error value is used. In such a system, there exists the possibility of a steady state error, which is a drawback for the proportional controller. Adding an integral component to the proportional controller eliminates this steady state error.

The equation for a proportional plus integral (PI) controller is:

$$v(t) = (k_1 \times e(t) + k_2 \times \int e(t) dt)$$

To be useful for a microcontroller-based (discrete) system, the integral is approximated by a running sum of the error signal. Thus, an equation can be expressed as follows called Equation 1:

$$v[k] = \left(C1 \times e[k] + C2 \times \sum_{j=0}^{k-1} e[j] \right)$$

where C1 and C2 are constants.

Equation 1 is the position algorithm. A better representation for Equation 1 is described in Equation 2, as follows:

$$v[k-1] = \left(C1 \times e[k-1] + C2 \times \sum_{j=0}^{k-2} e[j] \right)$$

Subtracting Equation 2 from Equation 1 and rearranging the terms yields Equation 3, as follows:

$$v[k] - v[k-1] = (Kp \times e[k] + Ki \times e[k-1])$$

where Kp and Ki are the proportional and integral constants, respectively.

Equation 3 is the velocity algorithm. It is a convenient expression, as only the incremental change in the manipulated variable is calculated.

For a detailed discussion on controllers, see [Reference](#) on page 8.

Charging and Charge Termination Techniques

Different battery types require different charging methods. The basic charging methods are the constant current and constant voltage charging. The NiCd and NiMH batteries are charged using the constant current method, whereas the SLA and Li-Ion batteries are charged via the constant voltage method. An on/off current limiter is required when performing constant voltage charging. These charging methods are based on the type of battery and the present state of charge for that battery.

In a constant current method of charging, fast charging occurs when the charging current equals the rated battery capacity, C. Fast charging requires constant monitoring of battery parameters and precise termination techniques. It is therefore important to know when to terminate charging.

The behavior of different batteries near full charge varies and demands different termination techniques. The most common termination techniques are the negative ΔV , zero ΔV , and the absolute battery voltage, all of which are based on battery types. For more information, see [Appendix D—Battery Technology](#) on page 15.

Safety Techniques

A battery charger must ensure the safety of batteries. Battery safety is implemented by monitoring the battery terminal voltage and current against the battery ratings provided by the manufacturer. When battery ratings are exceeded, the charging voltage or current is switched off.

Z8 Encore!-Based Battery Charger

This section offers an overview of the functional architecture of the battery charger implementation using Z8 Encore!.

Hardware Architecture

The Z8 Encore!-based charger features the following hardware blocks. [Figure 2](#) displays the following hardware blocks:

- Z8 Encore! MCU
- Step-down DC–DC (buck) converter
- Feedback section
- Battery selector (jumper settings)
- LED status indicators

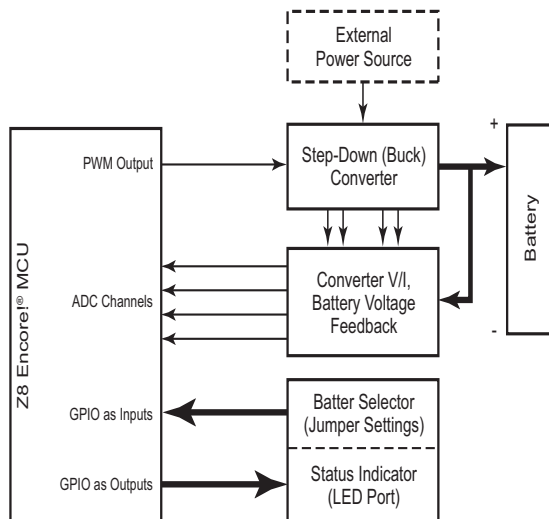

Figure 2. Block Diagram of Battery Charger Hardware

In this application, the Z8 Encore! MCU's Ports E and H are used as GPIO; Port B is used as an ADC input. Timer1 is used in PWM mode and the output is tapped at the pin PC1/Timer1 out.

The step-down DC–DC (buck) converter provides appropriate voltage or current for the set battery type and parameters. The buck converter modulates a higher voltage (from the external source) with a varying pulse width (PWM method) to generate a lower voltage. The pulse width is controlled by the control algorithm based on the values obtained from the feedback section. The output of the external source is preferably set to twice the value of the converter output voltage (V_{OUT}).

The feedback section consists of three differential amplifiers/attenuators. The corresponding parameters are the converter voltage (V_{OUT}), battery voltage (V_{BATT}), and battery current (I_{BATT}). The battery current and the converter current are the same.

The battery type is selected by setting one of the four jumpers provided. The jumper status is read initially, and the corresponding routine is selected for charging.

The charger indicates the charger status via LEDs, which are used to indicate various states such as successful completion of charging, safety error, no battery selection, and the specific battery type undergoing the charging process. [Table 1](#) lists the status indicators along with a brief description.

Table 1. LED Status Indicators

LED	Status	Description
D4	ON	SLA battery is selected and charging is ON.
D5	ON	NiCad battery is selected and charging is ON.
D6	ON	NiMH battery is selected and charging is ON.
D7	ON	Li-Ion battery is selected and charging is ON.
D8	ON	No battery is selected.
D9	ON	Safety error—charging is aborted.
D10	ON	Charging is successfully completed.

For the battery charger schematics, see [Appendix B—Schematics](#) on page 10.

Software Implementation

All Z8 Encore! peripherals are initialized to the required mode of operation. The jumper settings are read and the battery type is validated. When the battery type is fixed, the battery parameters are loaded into the variables. At present, these battery parameters are defined in the header file.

Initially, based on battery ratings, each module sets the safety and termination thresholds. Then type-dependent settings, such as converter voltage, current outputs, and current limit are calculated. When these one-time calculations are completed, the charger software enters an infinite loop, which is broken only by a successful charge completion or a safety error.

Inside the loop, the ADC reads the actual values for the converter output voltage, the battery voltage, and the current. The ADC measures the output voltage and output current of the DC–DC converter as a feedback to the controller. It measures the voltage at the battery terminals as an input to determine the charge termination.

When the actual values are known, they are checked for safety limit compliance. The safety routine is responsible for the overall safety features associated with the battery charger. The charger ensures safety by comparing the actual converter voltage and battery voltage with the calculated thresholds. Crossing these thresholds switches off the PWM output, which turns off the converter output and terminates charging functions. Such termination protects the batteries in case of a device failure. The LED status indicator reflects an unsuccessful termination.

If everything is within limits, the battery is tested for full charge. Full charge is tested using different methods for different batteries (see [Appendix D—Battery Technology](#) on page 15). If the battery is

fully charged, charging terminates and the LED indicators are updated. If the battery requires further charging, the controller calculates the required duty cycle for maintaining the setpoint at the converter output.

The controller implements proportional plus integral (PI) control to derive the PWM output based on the equations mentioned in the [Theory of Operation](#) on page 2. The timer ISR is invoked every 5 ms. The PWM value computed by the controller is loaded into the PWM generators to be sent out via the output pin.

The 16-bit timer PWM mode offers a programmable switching frequency based on the reload value. This flexibility allows you to trade off between accuracy and frequency of the PWM switching signal. The higher the frequency, the lesser the reload value and the lower the resolution in the pulse width variation; and vice versa.

The timer ISR also updates the charge termination variables every 10 seconds.

Testing

This section contains a detailed test procedure to demonstrate the working of the Z8 Encore! battery charger as described in this Application Note. The test setup to demonstrate the battery charger using Z8 Encore! is displayed in [Figure 3](#).

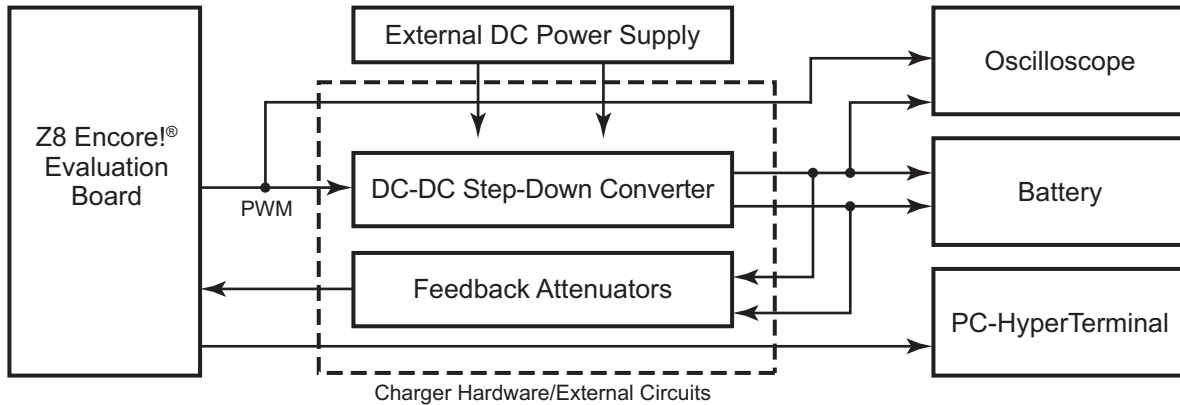

Figure 3. Battery Charger Test Setup

The test setup consists of an oscilloscope and a PC running the HyperTerminal application. For testing, the Z8 Encore! Evaluation Board is used with the DC–DC converter and the feedback circuits. An external DC source supplies necessary voltage and current for the various circuits involved.

The external DC power supply provides two different voltages to the charger circuits—the DC–DC step-down converter and the feedback attenuators. The operational amplifier based feedback attenuator circuits are fed with a 12 V supply. The DC–DC converter works on a 8–12 V DC input for the

batteries tested. The control algorithm provides the necessary line regulation to sustain the voltage variation at the input.

During testing, HyperTerminal is set at 57600 baud, 8-bit data, no parity, 1 stop bit, and no flow control.

Table 2 lists the equipment used to test the Z8 Encore! based battery charger.

Table 2. Z8 Encore! Battery Charger Test Equipment

Z8 Encore! Evaluation Board (Z8ENCORE000ZCO)			
External power supply			
Oscilloscope (Tektronix TDS 724D; 500 MHz/1 GSps)			
Multimeter			
PC (The HyperTerminal utility is used via the COM2 port of the PC)			
Batteries Used	Make	Type	Ratings
BP–T40	Sony	Sealed Lead Acid	4 V, 500 mAh
BP–T16	Sony	Nickel Cadmium	3.6 V, 270 mAh
CP2010H T–014	Panasonic	Nickel Metal Hydride	3.6 V, 150 mAh

The circuits are connected as per the schematics in [Appendix B—Schematics](#) on page 10.

When the external power supply and the Evaluation Board power supply are switched on, the PWM waveforms are observed on the oscilloscope. The battery/converter's actual values are indicated in the HyperTerminal window. The LED status indicators, as displayed in [Figure 2](#), reflect the charging status during the charging operation. [Figures 4, 5, and 6](#) display the test results obtained while charging various types of batteries.

For SLA batteries, initially the current is effectively limited to 200 mA; it continually falls while battery voltage increases. The charging profiles also demonstrate the constant voltage output (V_{out}) of the DC-DC converter at 4900 mV. See [Figure 4](#).

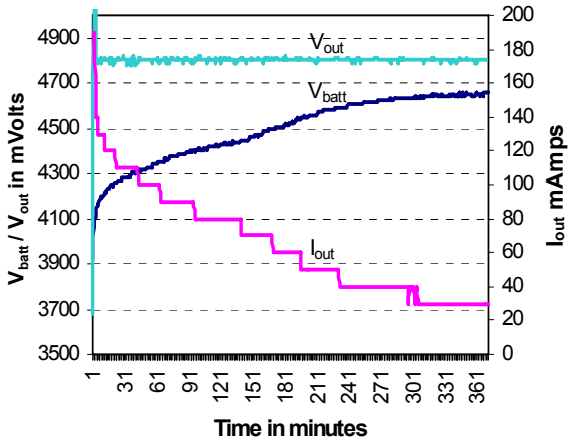

Figure 4. SLA Charging Profile

The NiCd charging profile displayed in [Figure 5](#) indicates a marked hump towards the full charge, before dropping down. The software effectively detects this drop and the charging is terminated.

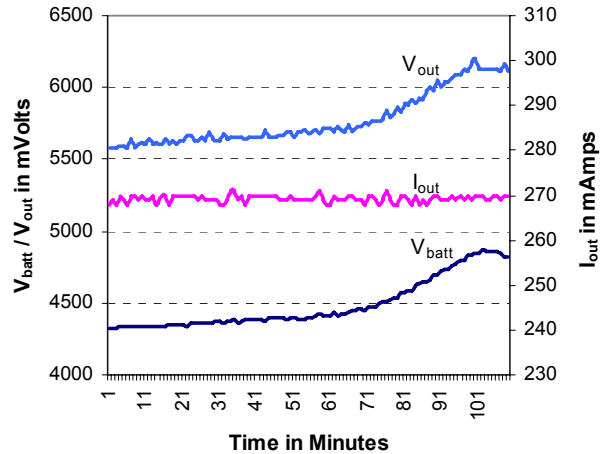

Figure 5. NiCd Charging Profile

The NiMH charging profile displayed in [Figure 6](#), lacks a significant drop and is thus terminated using the zero ΔV termination scheme.

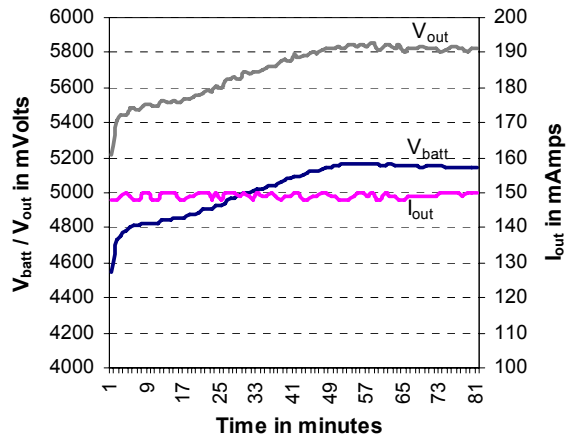

Figure 6. NiMH Charging Profile

The charging profiles for NiCd and NiMH batteries demonstrate constant current outputs of 270 mA and 150 mA respectively. These are equal to their rated battery capacity measured in mAh. The

charging times for NiCd and NiMH are 1 hour, 45 minutes and 1 hour, 25 minutes, respectively.

► **Note:** *Because the SLA and Li-Ion batteries follow similar charging (constant voltage with limited current) and termination profiles (absolute voltage), only the SLA battery was charged. The results are provided in this document.*

Summary

This Application Note demonstrates the use of Z8 Encore! in a battery charger implementation. Ordinary battery chargers can charge batteries of a particular type and of a particular voltage. The Z8 Encore!-based hardware/software provides flexibility such that batteries of different types can be charged with the same charger.

The Z8 Encore! 10-bit ADC ensures accurate charge termination, facilitating faster recharge. Such termination avoids overcharging and prolongs battery life. The flexibility of the PWM mode allows for accurate DC–DC buck/step-down converter implementation with excellent line/load regulation.

The test results clearly demonstrate the charging and termination mechanisms used by the charger to successfully charge different battery types.

Reference

The documents associated with Z8 Encore![®] available on www.zilog.com and electronics references are provided below:

- High Frequency Switching Power Supplies: Theory and Design; author: George Chryssis; ISBN: 0-07-010949-4; Publisher: McGraw-Hill Book Company
- Digital Control Systems, Volume 1—Fundamentals, Deterministic Control; author: Rolf Isermann; ISBN: 0-387-50266-1; Publisher: Springer Verlag
- Yuasa Technical Manual—<http://www.yuasabatteries.com/literature.asp>
- Duracell—<http://www.duracell.com/batteries>
- Eveready/Energizer—<http://data.energizer.com>
- Panasonic Li-Ion battery documents—<http://www.panasonic.com/industrial/battery/oem/chem/lithion/index.html>
- Sanyo—<http://www.sanyo.com/industrial/batteries/index.html>
- Z8 Encore![®] Flash Microcontroller Development Kit User Manual (UM0146)
- Power Electronics Design Handbook: Low Power Components and Applications; author: Nihal Kularatna; ISBN: 0-7506-7073-8; Publisher: Oxford; Newnes, 1998

Appendix A—Glossary

Definitions for terms and expansions for abbreviations used in this application note that are not commonly used are listed in [Table 3](#).

Table 3. Glossary

Term/Abbreviation	Definition/Expansion
ADC	Analog-to-Digital Converter
ISR	Interrupt Service Routine
Li-Ion	Lithium Ion
mAh	milli-Ampere-hour: a unit of battery capacity
NiCd	Nickel Cadmium
NiMH	Nickel Metal Hydride
PI	Proportional plus Integral
PWM	Pulse Width Modulation
SLA	Sealed Lead Acid

Appendix B—Schematics

This section provides the schematics for the Z8 Encore! battery charger implementation

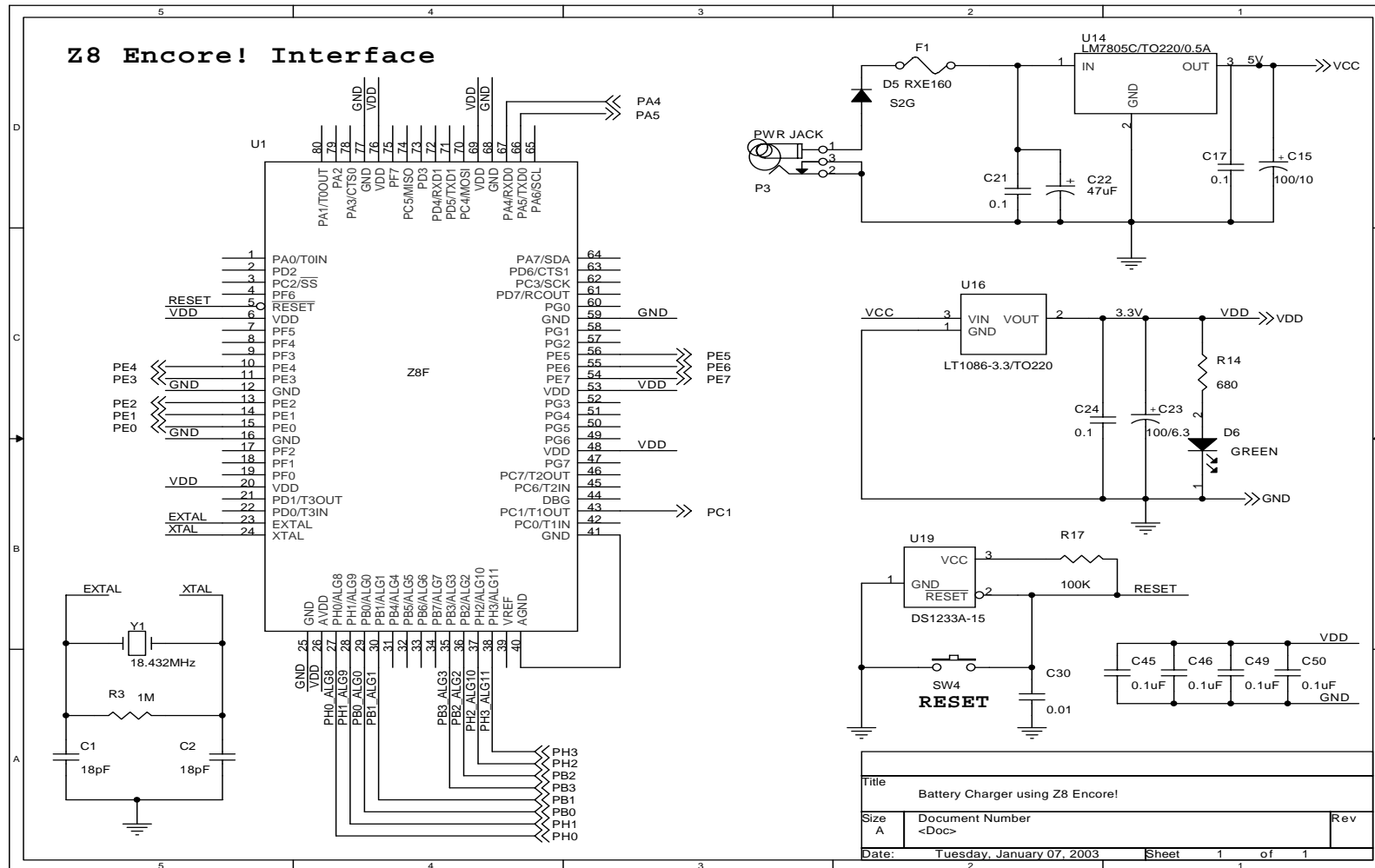

Figure 7. Schematic for Z8 Encore! Interface

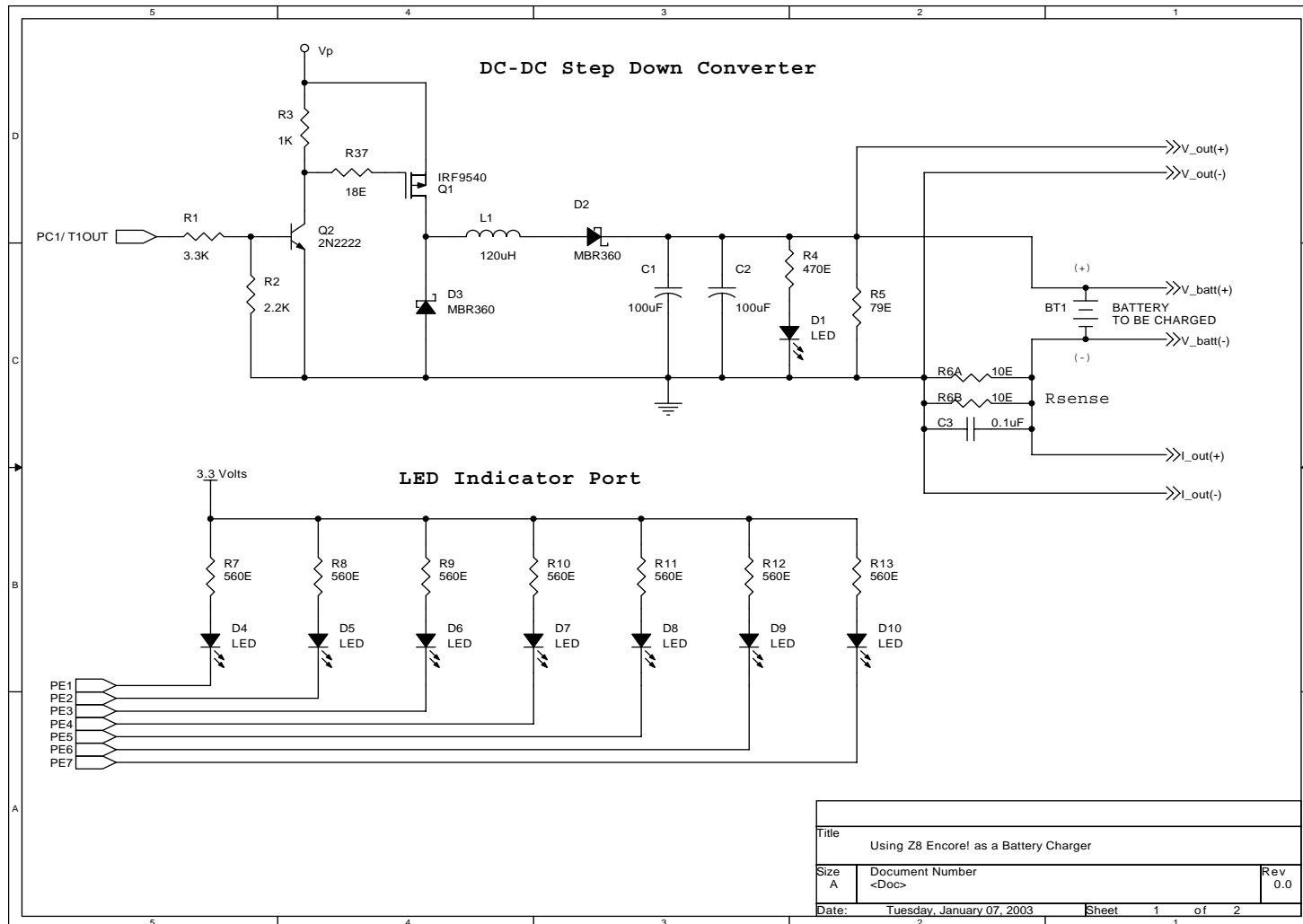

Figure 8. DC-DC Step-Down Converter and LED Indicator Port

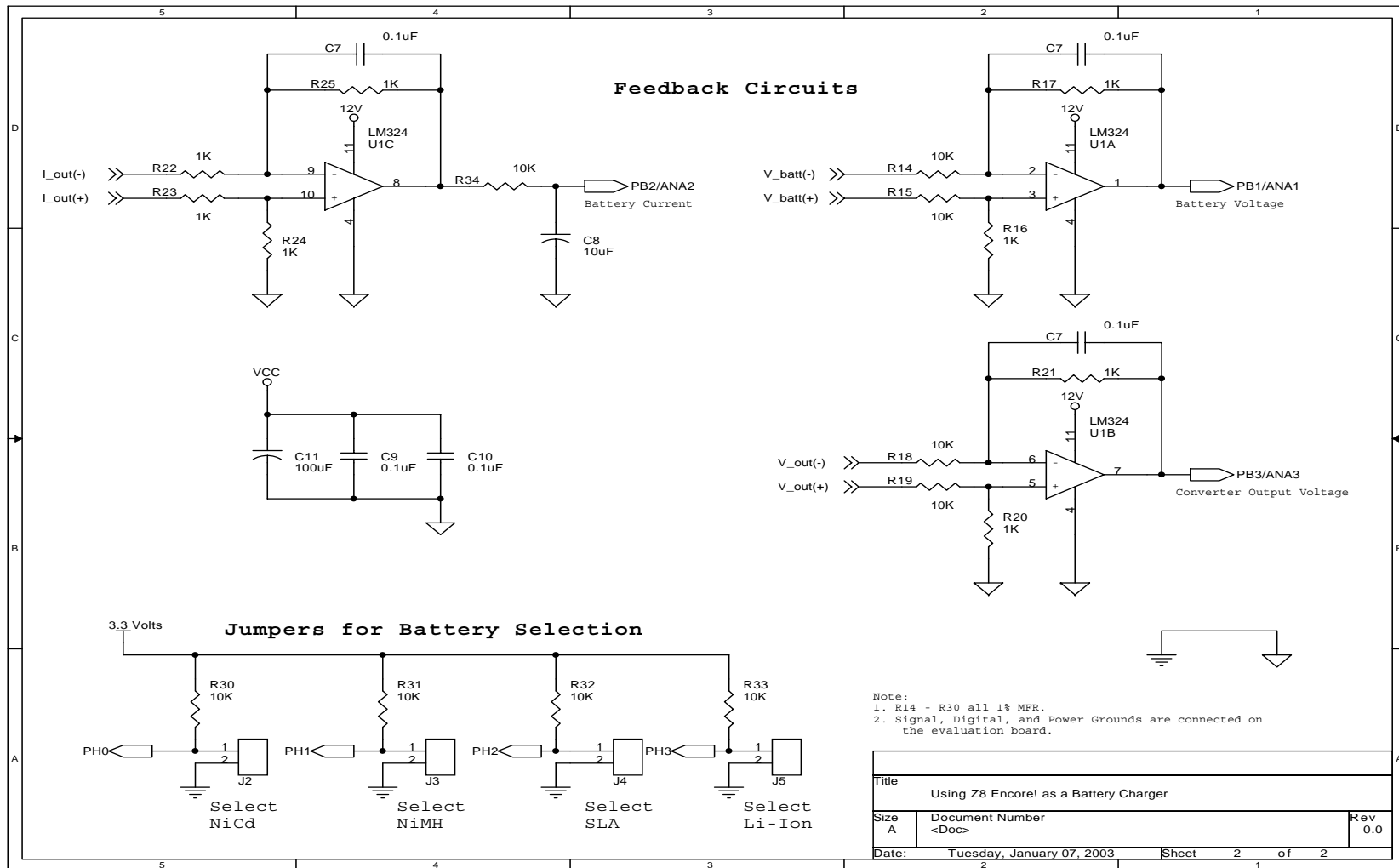

Figure 9. Feedback Section and Battery Type Selector Jumper Settings

Appendix C—Flowcharts

The main battery-charging routine is displayed in [Figure 10](#).

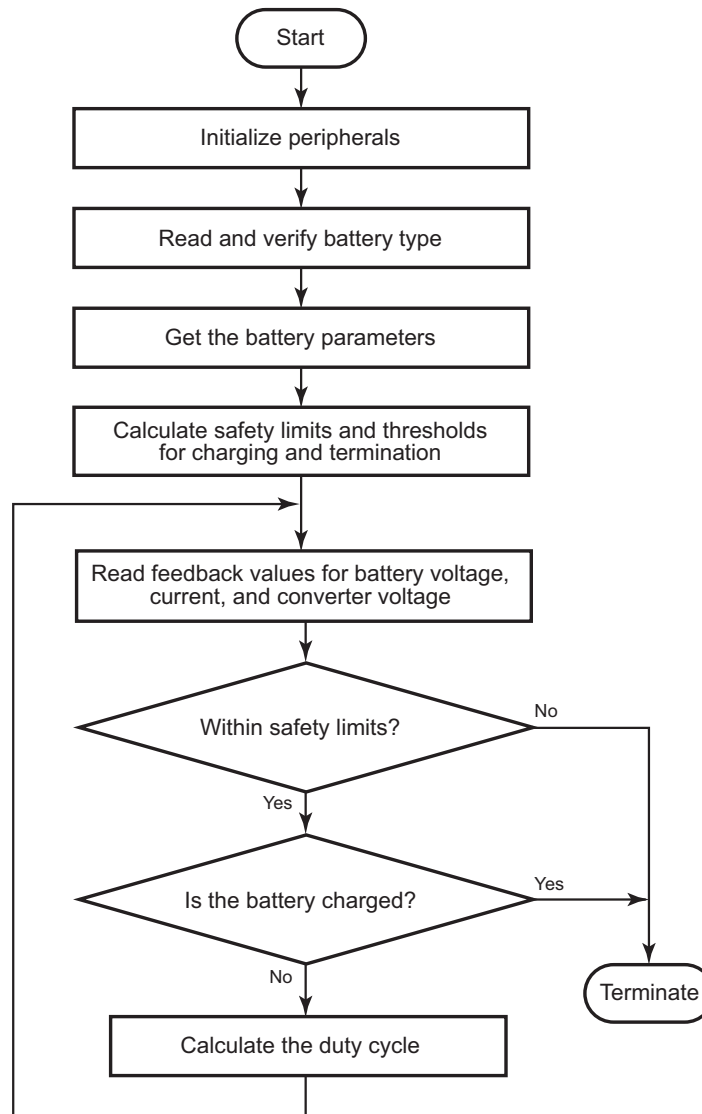

Figure 10. Flowchart for the Main Routine

The ISR return routine is displayed in [Figure 11](#).

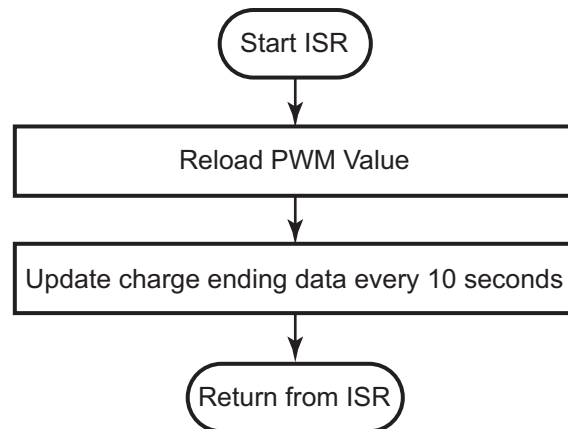

Figure 11. Flowchart for the ISR Return Routine

Appendix D—Battery Technology

The four mainstream battery chemistries discussed in this Application Note feature different charging and discharging characteristics. Long-term battery life and performance are critically dependent upon how batteries are charged. Therefore, it is important to charge batteries with a mechanism specific to their requirement.

It is also important to know when to terminate charging, because overcharging of a battery invariably results in poor performance and can damage the battery in extreme cases. Different battery types behave differently near full charge condition and thus require specific charge termination techniques. During charging, all batteries exhibit a marked rise in voltage above the rated battery voltage.

The four major rechargeable battery types—SLA, NiCd, NiMH, and Li-Ion, are briefly discussed below. For further details, see [Reference](#) on page 8.

Sealed Lead Acid (SLA)

Sealed Lead Acid batteries are most commonly seen in automobiles. The single cell voltage for SLA is 2 V. According to their use, several such cells are connected in series to get higher voltages such as 12 V/24 V.

SLA batteries are usually charged with a constant voltage supply of 2.45 V per cell. For this Application Note, 4.90 V is used as the charging voltage for the 4 V SLA battery.

At the start of charging, depending on their state of charge, SLA batteries require huge amounts of current. If this current uptake is not controlled, the battery electrolyte may boil, producing gasses inside the battery. It is therefore necessary to limit the charging current. When the battery achieves some charge, the current is limited and constant voltage charging is enforced.

The charge termination mechanism is simple and is achieved as battery voltage reaches the charging voltage. At the same time, there is a corresponding drop in charging current.

Nickel Cadmium (NiCd)

NiCd batteries are used in camcorders, Walkmans, and other similar consumer portable equipment. The single-cell voltage for NiCd batteries is 1.2 V.

These batteries are charged using the constant current charging method. While charging, as the voltage crosses the full charge point, it starts dropping. This drop is approximately 15 mV per cell in the battery. This drop is recognized as a full charge condition, and charging is terminated. This termination mechanism is named as $-\Delta V$ termination. During charging, battery voltage rises to 1.65 V per cell.

The disadvantage of the NiCd battery is that the battery must be periodically discharged to protect performance. In battery parlance, this phenomenon is known as *memory effect*.

Nickel Metal Hydride (NiMH)

NiMH batteries exhibit higher power density compared to NiCd batteries. The per-cell voltage of the NiMH battery type is 1.2 V, similar to NiCd batteries.

NiMH batteries are charged via the constant current charging method. While charging, as the voltage crosses the full charge point, the voltage drop is not as low as for the NiCd batteries. As a consequence, $-\Delta V$ charge termination is usually not recommended for these batteries. Instead of the fall in cell voltage, the battery tends to plateau after a small drop. This flat region is the preferred indication for full battery charging, rather than the drop. Consequently, this termination mechanism is named *zero ΔV termination*.

NiMH batteries do not suffer from memory effect as do NiCd batteries. As a result, they replace NiCd battery types in applications such as cell phones because the increase in price is justified by the reduction in weight and absence of memory effect.

Lithium Ion (Li-Ion)

Li-Ion batteries are lighter in weight than NiCd and NiMH batteries. Available with a high voltage rating of 3.7 V, one Li-Ion battery can replace three NiCd/NiMH battery types. These two features make Li-Ion high-energy density batteries. They exhibit flat discharge characteristics and are free from memory effect.

If the starting voltage of these batteries is initially too low, a small constant current is applied until the battery reaches a certain threshold specified by the manufacturer. The battery is charged with constant voltage when this threshold is crossed. Charging is terminated when battery voltage reaches the rated voltage.



Warning: DO NOT USE IN LIFE SUPPORT

LIFE SUPPORT POLICY

ZILOG'S PRODUCTS ARE NOT AUTHORIZED FOR USE AS CRITICAL COMPONENTS IN LIFE SUPPORT DEVICES OR SYSTEMS WITHOUT THE EXPRESS PRIOR WRITTEN APPROVAL OF THE PRESIDENT AND GENERAL COUNSEL OF ZILOG CORPORATION.

As used herein

Life support devices or systems are devices which (a) are intended for surgical implant into the body, or (b) support or sustain life and whose failure to perform when properly used in accordance with instructions for use provided in the labeling can be reasonably expected to result in a significant injury to the user. A critical component is any component in a life support device or system whose failure to perform can be reasonably expected to cause the failure of the life support device or system or to affect its safety or effectiveness.

Document Disclaimer

©2008 by Zilog, Inc. All rights reserved. Information in this publication concerning the devices, applications, or technology described is intended to suggest possible uses and may be superseded. ZILOG, INC. DOES NOT ASSUME LIABILITY FOR OR PROVIDE A REPRESENTATION OF ACCURACY OF THE INFORMATION, DEVICES, OR TECHNOLOGY DESCRIBED IN THIS DOCUMENT. ZILOG ALSO DOES NOT ASSUME LIABILITY FOR INTELLECTUAL PROPERTY INFRINGEMENT RELATED IN ANY MANNER TO USE OF INFORMATION, DEVICES, OR TECHNOLOGY DESCRIBED HEREIN OR OTHERWISE. The information contained within this document has been verified according to the general principles of electrical and mechanical engineering.

eZ8, Z8, Z8 Encore!, and Z8 Encore! XP are trademarks or registered trademarks of Zilog, Inc. All other product or service names are the property of their respective owners.